

Trademarks

LAUNCH is a registered trademark of LAUNCH TECH CO., LTD. in China and other countries. All other marks are trademarks or registered trademarks of their respective holders.

Copyright Information

Copyright © 2023 by LAUNCH TECH CO., LTD. (also called LAUNCH for short). All rights reserved. No part of this publication may be reproduced, stored in a retrieval system, or transmitted in any form or by any means, electronic, mechanical, photocopying and recording or otherwise, without the prior written permission.

Statement: LAUNCH owns the complete intellectual property rights for the software used by this product. For any reverse engineering or cracking actions against the software, LAUNCH will block the use of this product and reserve the right to pursue their legal liabilities.

Disclaimer of Warranties and Limitation of Liabilities

All information, illustrations, and specifications in this manual are based on the latest information available at the time of publication.

The right is reserved to make changes at any time without notice. We shall not be liable for any direct, special, incidental, indirect damages or any economic consequential damages (including the loss of profits) due to the use of the document.

Important Safety Precautions

To avoid personal injury, property damage, or accidental damage to the product, read all of the information in this section before using the tool.

DANGER

- When an engine is operating, keep the service area well-ventilated or attach a building exhaust removal system to the engine exhaust system. Engines produce various poisonous compounds (hydrocarbon, carbon monoxide, nitrogen oxides, etc.) that cause slower reaction time and result in death or serious personal injury.
- Please use the included battery and power adaptor. Risk of explosion if the battery is replaced with an incorrect type.
- DO NOT attempt to operate the tool while driving the vehicle. Have second person operate the tool. Any distraction may cause an accident.

WARNING

- Always perform automotive testing in a safe environment.
- Do not connect or disconnect any test equipment while the ignition is on or the engine is running.
- Before starting the engine, put the gear lever in the Neutral position (for manual transmission) or in the Park (for automatic transmission) position to avoid injury.
- NEVER smoke or allow a spark or flame in vicinity of battery or engine. Do not operate the tool in explosive atmospheres, such as in the presence of flammable liquids, gases, or heavy dust.
- Keep a fire extinguisher suitable for gasoline/chemical/electrical fires nearby.
- Wear an ANSI-approved eye shield when testing or repairing vehicles.
- Put blocks in front of the drive wheels and never leave the vehicle unattended while testing.

LAUNCH

- Use extreme caution when working around the ignition coil, distributor cap, ignition wires and spark plugs. These components create hazardous voltage when the engine is running.
- To avoid damaging the tool or generating false data, please make sure the vehicle battery is fully charged and the connection to the vehicle DLC (Data Link Connector) is clear and secure.
- Automotive batteries contain sulfuric acid that is harmful to skin. In operation, direct contact with the automotive batteries should be avoided. Keep the ignition sources away from the battery at all times.
- Keep the tool dry, clean, free from oil, water or grease. Use a mild detergent on a clean cloth to clear the outside of the equipment when necessary.
- Keep clothing, hair, hands, tools, test equipment, etc. away from all moving or hot engine parts.
- Store the tool and accessories in a locked area out of the reach of children.
- Do not use the tool while standing in water.
- Do not expose the tool or power adapter to rain or wet conditions. Water entering the tool or power adaptor increases the risk of electric shock.
- This tool is a sealed unit. There are no end-user serviceable parts inside. All internal repairs must be done by an authorized repair facility or qualified technician. If there is any inquiry, please contact the dealer.
- Keep the tool far away from magnetic devices because its radiations can damage the screen and erase the data stored on the tool.
- Do not attempt to replace the internal rechargeable lithium battery. Contact the dealer for factory replacement.
- Do not disconnect battery or any wiring cables in the vehicle when the ignition switch is on, as this could avoid damage to the sensors or the ECU.
- Do not place any magnetic objects near the ECU. Disconnect the power supply to the ECU before performing any welding operations on the vehicle.
- Use extreme caution when performing any operations near the ECU or sensors. Ground yourself when you disassemble PROM, otherwise ECU and sensors can be damaged by static electricity.
- When reconnecting the ECU harness connector, be sure it is attached firmly, otherwise electronic elements, such as ICs inside the ECU, can be damaged.
- Because there are various procedures, techniques, tools, and parts for servicing vehicles, as well as the skill of the person doing the service work, the technician must be well knowledgeable of the vehicle and the system being tested.
- The vehicle parts and the X-PROG 3 components are welded at a constant temperature.
- When welding vehicle parts with the X-PROG 3 components, the unit is powered off and is grounded.

Table of Contents

1 Introduction 1

1.1 Product Profile 1

1.2 Package List 1

1.3 Components & Controls 2

 1.3.1 Display Tablet 2

 1.3.2 SmartLink C V2.0 Device 4

 1.3.3 Docking Station 5

1.4 Technical Specifications 6

2 Initial Setup 8

2.1 Charging the Tablet 8

2.2 Screen Layout 8

2.3 Adjusting Screen Brightness 8

2.4 Changing Language 9

2.5 Network Setup 9

3 Getting Started 10

3.1 Register & Update 10

3.2 Home Screen 11

4 Connections 13

4.1 Preparation 13

4.2 Vehicle Connection 13

5 Key Immobilizer & Immobilizer Programming 15

5.1 Key Immobilizer (IMMO) 15

 5.1.1 Vehicle connection 15

 5.1.2 Immobilizer operations 15

5.2 Immobilizer Programming (IMMO PROG) 19

5.3 Key Programmer 19

6 Diagnosis 20

6.1 Intelligent Diagnose 20

6.2 Local Diagnose 21

 6.2.1 Health report (Quick Test) 23

 6.2.2 System scan 25

 6.2.3 System selection 25

 6.2.4 ADAS calibration 29

6.3 Remote Diagnose 29

 6.3.1 SmartLink Super Remote Diagnostics 29

 6.3.2 X431 Remote Diagnostics 31

6.4 Diagnostic History 36

6.5 Feedback 36

7 Service (Reset) Function	37
8 Software Update	38
8.1 Update Diagnostic Software & APP	38
8.2 Update IMMO&IMMO PROG Software	38
8.3 Renew Subscription	38
9 ADAS (Calibration)	39
10 TPMS	40
11 Other Modules	42
11.1 Common Apps.....	42
11.1.1 Vehicle Coverage	42
11.1.2 User Info	42
11.1.3 Toolbox	45
11.2 Bulit-in Apps	45
11.2.1 Tablet Settings	46
11.2.2 TeamViewer QS	46
11.2.3 Wireless Upgrade	46
11.2.4 File Explorer	46
12 J2534 Reprogramming Using SmartLink C	47
13 FAQ	48
13.1 About X-431 IMMO PAD	48
13.2 About SmartLink Diag.	49
Warranty	50

1 Introduction

1.1 Product Profile

This Android OS-based, tablet-style diagnostic tool incorporates the best possible coverage of OE-level diagnostics with multitasking capable software. Using the powerful 8-core 2.0GHz processor and a 10.1 inch sunlight readable capacitive touch screen with a resolution of 1920 x 1200 pixels, it delivers quick and complete diagnostic functionalities which technicians need to diagnose, research and repair vehicles in one solution.

It has the following features: IMMO (immobilizer), IMMO PROG (Immobilizer Programming), key programmer, intelligent diagnose, local diagnose, SmartLink super remote diagnose, X-431 remote diagnose, service function, one-click update, diagnostic history, feedback, vehicle coverage lookup, ADAS calibration and add-on modules etc.

1.2 Package List

The following packing list is for reference purpose only. For different destinations, the accessories may vary. For details, please consult from the local dealer or check the packing list supplied with this tool together.

No.	Item	Description	Qt.
1	Display tablet	Indicates the test results.	1
2	SmartLink C V2.0	Connects to vehicle's DLC port to access vehicle's live data.	1
3	Diagnostic cable	Connects the SmartLink C device to the OBD II vehicle's DLC.	1
4	Crossover cable	Connects the SmartLink C device to the modem when performing SmartLink Super remote diagnostics operations.	1
5	Power adaptor	Charges the tablet.	2
6	Data cable	Connects the SmartLink C device to PC for J2534 reprogramming/Connects the SmartLink C device to diagnostic tablet to perform vehicle diagnosis.	1
7	Password envelope	A piece of paper bearing Product S/N and Activation Code, which is needed for product registration.	1
8	Docking station	Charges the tablet.	1
9	X-PROG 3 immobilizer programmer kit	Includes the X-PROG 3 and the accessory.	1
10	Quick start guide	A brief tutorial of the product. For more details, refer to the In-app User Manual.	1

1.3 Components & Controls

There are two main components to the diagnostic system: display tablet and SmartLink C V2.0 device.

1.3.1 Display Tablet

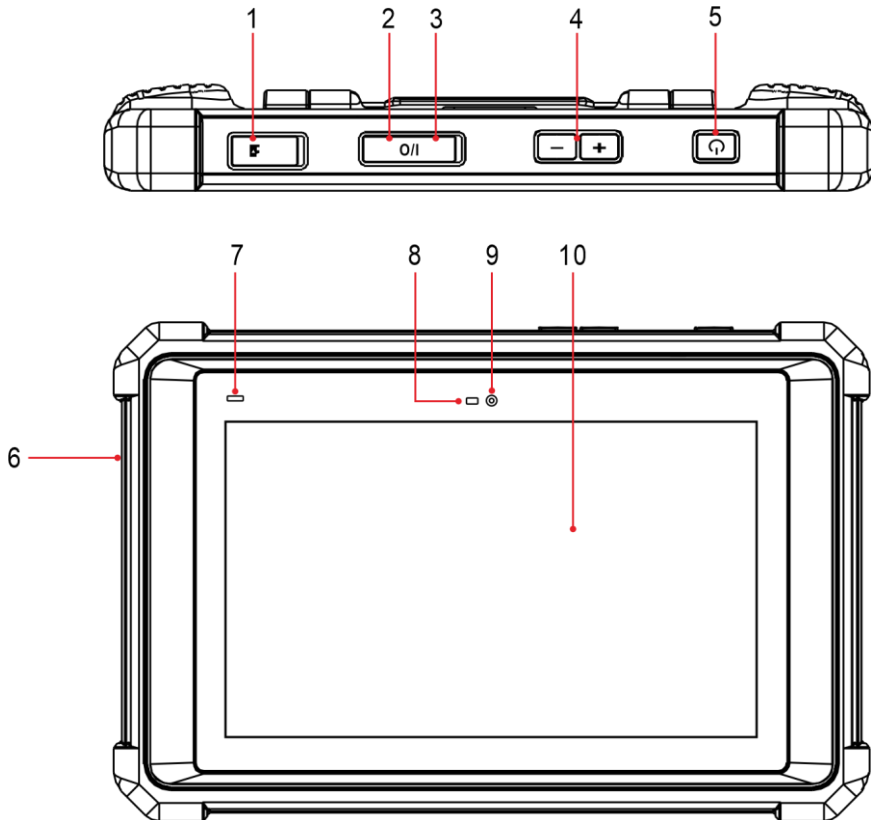

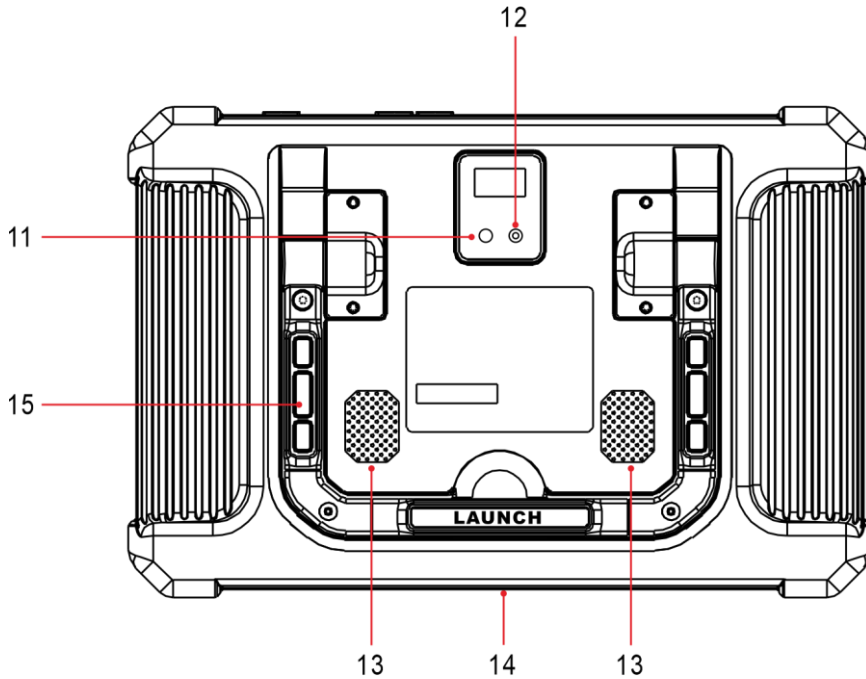

1. Memory Card Slot

Insert a memory card for storage extension.

2. Data I/O Port

- Connect it to the SmartLink C V2.0 device to perform vehicle diagnosis.
- Connect it to the add-on module to extend the functions of the diagnostic tablet.

3. Charging Port

Charge the tablet via the power adaptor.

4. Volume Buttons

Adjust the volume.

 Note: Press and hold [POWER] and [VOL -] key to capture the current screenshot.

5. Power/Screen Lock Button

To turn the tablet on/off with long press, or lock the screen with short press.

6. Microphone

Convert voice into an electrical signal.

7. Charging LED

It illuminates red while the tablet is charging. Once charging is finished, it will illuminate solid green.

8. Ambient Light Sensor

Sense the amount of the ambient light present.

9. Front Camera

Snapshot the view ahead the screen.

10. Touch Screen

Indicate the test results.

11. Camera Flash

LAUNCH

Produce a flash of artificial light.

12. **Rear Camera**

Snapshot the view in front of the tablet.

13. **Audio Speaker**

Convert an electrical audio signal into a corresponding sound.

14. **Charging Slot**

Align it with the charging slot on the docking station to charge the tablet. Refer to Chapter 1.3.3.

15. **Adjustable Kickstand**

Flip out it to any angle and work comfortable at your desk, or hang it on automotive part.

1.3.2 SmartLink C V2.0 Device

The SmartLink C V2.0 device features powerful functions and it can be applied in the following situations:

- 1). When as a VCI (Vehicle Communication Interface), it needs to work in conjunction with the **Diagnose** module of the tablet, which is used to obtain vehicle data, and then send it to the tablet for analysis wirelessly or via data cable.
- 2). When as a SmartLink C (Customer) dongle, it does not communicate with the tablet, but it needs to work together with the **SmartLink** module of the tablet. The tablet is mainly used to issue remote diagnostic requests, and the SmartLink C dongle is networked to receive and execute commands from the remote SmartLink B (Business).

Note: For detailed operations, please refer to Chapter 6.3.

- 3). When as a local J2534 PassThru device, it can be used in conjunction with the PC installed with OEM diagnostic software.

Note: For detailed operations, please refer to Chapter 10.

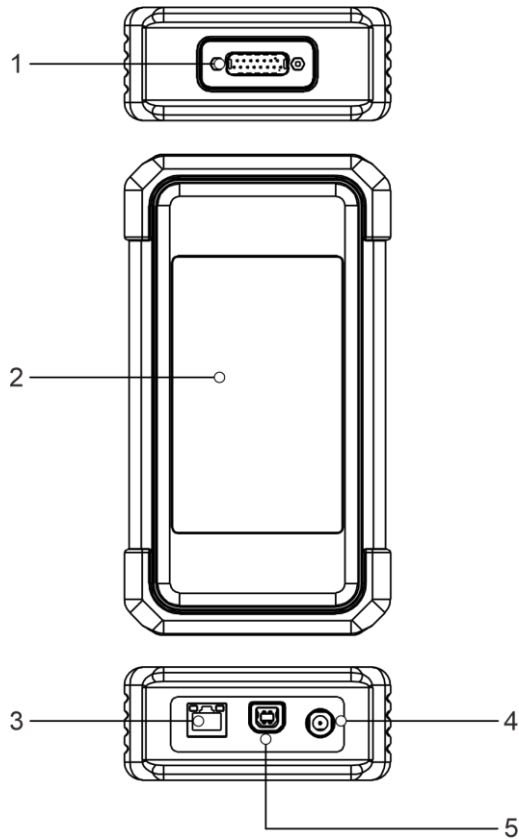

1. DB-15 diagnostic connector

Connect it to the vehicle's DLC (Data Link Connector) port via the diagnostic cable.

2. Touch screen

3. LAN/WAN port

Connect it to the modem via the crossover cable. It only applies to the SmartLink Super Remote Diagnostics.

4. DC-IN power jack

It can obtain power via connecting the diagnostic cable to the vehicle's DLC port or connecting to an external DC power supply.

Warning: It is prohibited to connect this power jack to an external DC power supply when the SmartLink C V2.0 device is properly connected to the vehicle's DLC port.

No responsibility can be assumed for any damage or loss caused as a result of not strictly following the warning.

5. Data I/O port

- Connect it to the tablet to perform vehicle diagnosis.
- Connect it to the PC to perform J2534 reprogramming when as a J2534 PassThru device.

1.3.3 Docking Station

The docking station is used to charge the diagnostic tablet.

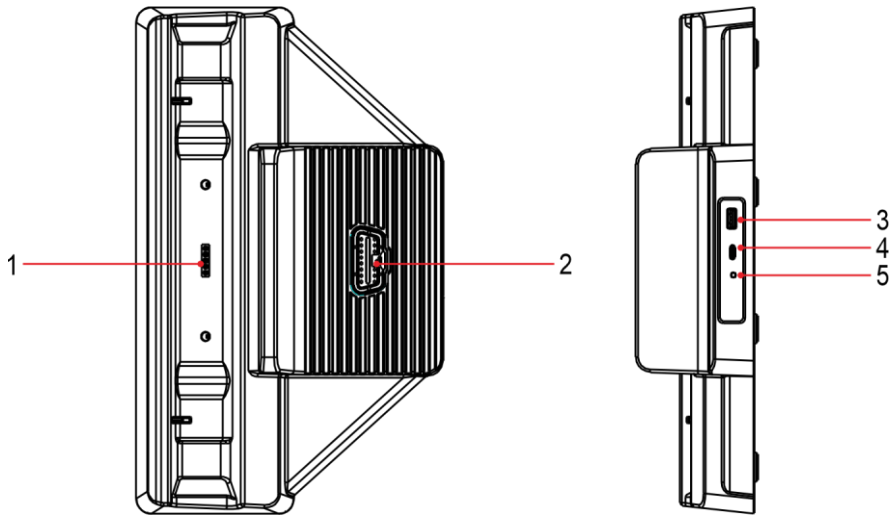

1. Charging slot

Charge the diagnostic tablet.

2. OBD II socket

Store the OBD II adaptor to avoid loss.

3. DC 5V OUT port

Reserved for charging other USB devices only.

4. Charging port

Use the power adaptor to supply power to the docking station through connection to AC outlet.

5. Power LED

Illuminates solid green when it is powered on.

1.4 Technical Specifications

1. Display tablet

CPU: 8-core Processor, 2.0GHz

Display: 10.1 inch touch screen with a resolution of 1920 x 1200P

Memory: 4GB

Hard Disk: 128GB

Connectivity:

- Wi-Fi (802.11 b/g/n/ac)
- Universal serial BUS Ports (1 x Type-C + 1 x Type-A)

Camera: 8MP front-facing camera + 13MP rear-facing camera

Sensor: Gravity Accelerometer, 3-Axis Acceleration Sensor

Operating temperature: 0°C ~ 50°C

Storage temperature: -20°C ~ 70°C

1.3.2 VCI (Vehicle Communication Interface)

Size: 200mm x 110mm x 47mm

LAUNCH

Working voltage: DC 9~36V

Power consumption: $\leq 6W$

Communication: wireless and wired

Working temperature: 0°C ~ 50°C

2 Initial Setup

2.1 Charging the Tablet

*Notes:

- Only use the included power adaptor to recharge the tablet. Use of any other adaptor will damage the tool. We assume no responsibility for damage or loss resulting from using other similar adaptors other than the specified one.
- Always charge on a non-flammable surface in a well-ventilated area.

To check the battery power level, press and hold the Power button about 3 seconds to turn on the tablet. Power level is indicated as a percentage in the upper right corner of the screen. If the power level drops below 10% while the tablet is on, a “Connect Charger” notification will appear on the screen.

1. Charging with the included 5V power adaptor

- 1) Connect one end of the power adaptor to charging port of the tablet, and the other end to the AC outlet.
- 2) The charging LED illuminates solid red and the charging symbol will appear on the screen.
- 3) Once it illuminates solid green, it indicates that the battery is fully charged. Disconnect the power adaptor from the AC outlet.







2. Charging with the docking station

- 1) Locate the charging slot on the bottom of the tablet and docking station. Align the charging slots, and then dock the tablet into the station to ensure that it is firmly seated on the docking station.
- 2) Insert one end of the included power cord to the charging port of the docking station, then the other end into the AC outlet. The charging LED illuminates solid red while charging.
- 3) Once it illuminates solid green, it indicates that the battery is fully charged. Disconnect the power adaptor from the AC outlet.

Press and hold the **POWER** button for about 3 seconds to turn on the tablet. The system starts initializing and then enters the home screen. To turn the tablet off, press and hold the **POWER** button until an option menu appears. Tap **Power Off**.

2.2 Screen Layout

The following on-screen buttons are available on the bottom of the screen.

-  - Tap to visit the official website.
-  - Tap to capture current screen and all captured screenshots are stored in the Screenshots folder.
-  - Shows whether the VCI is connected properly or not.
-  - Tap to display a list of applications that are currently running or recently used.
-  - Tap to jump to home screen.
-  - Tap to return to previous screen or exit the application.

2.3 Adjusting Screen Brightness

The tablet is equipped with a built-in light intensity sensor. It can adjust the screen brightness according to the ambient light intensity automatically. Alternatively, you can also adjust it manually.

LAUNCH

1. On the home screen, tap **Other Modules -> Built-in apps -> Tablet Settings -> Display -> Brightness level**.
2. Drag the slider to adjust it.

Alternatively, user may also slide the **Automatically brightness** switch to ON, and the system will automatically adjust the screen brightness.

*Tips: Reducing the brightness of the screen is helpful to save the power of the tablet.

2.4 Changing Language

The tablet supports multiple languages. To change the language of the tablet, please do the following:

1. On the home screen, tap **Other Modules -> Built-in apps -> Tablet Settings -> Language & input -> Language**.
2. Tap the desired language from the list and the system will change to the chosen language.

2.5 Network Setup

The tablet has dual built-in Wi-Fi communication modules. One is used to communicate with the tablet, and the other allows the tablet to get online. Once you're online, you can register your tool, update diagnostic software & APK, browse the Internet and send email on your network.

If the SmartLink C device is successfully activated, it will be automatically bound to the tablet. In this case it is not necessary for the user to manually configure it again.

*Note: Once WLAN is set as ON, the tablet will consume more power. While WLAN keeps unused, please turn it off to conserve battery power.

1. On the home screen, tap **Other Modules -> Built-in apps -> Tablet Settings -> WLAN**.
2. Tap or slide the Wi-Fi switch to ON, the tablet starts searching for all available wireless LANs.
3. Choose the desired Wi-Fi access point / network,
 - If the network you chose is open, you can connect directly;
 - If the selected network is encrypted, you have to enter the right security key (network password).

When this tool is in range, it will connect to the previously linked network automatically.

3 Getting Started

3.1 Register & Update

For initial use, the registration is the necessary first procedure to activate the tool.

After the tablet is initialized, tap **Login** on the upper right corner of the screen, the following screen will appear:

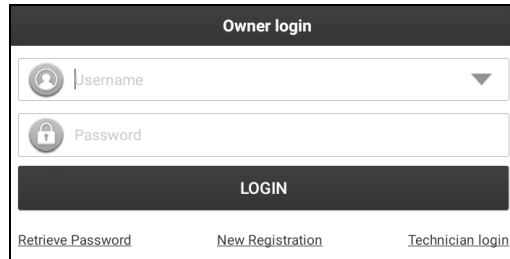

(If you are a new user, follow **A** to proceed.)

(If you have registered to be a member, go to **B** to login the system directly.)

(If you have bound a sub-account to this tool, go to **C** to login the system.)

(In case you forgot password, refer to **D** to reset a new password.)

A. If you are a new user, tap **New Registration** to enter sign-up page.

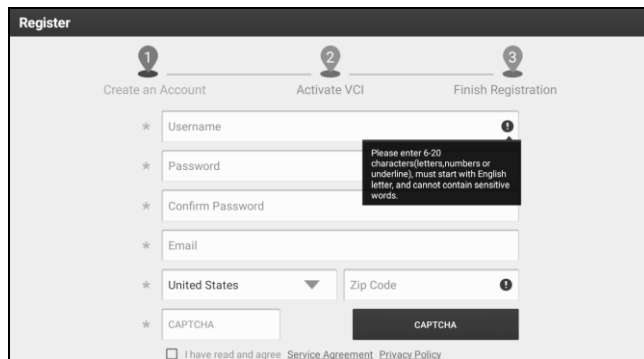

In the above figure, fill in the information in each field. After inputting, tap **Register**, the following screen will appear:

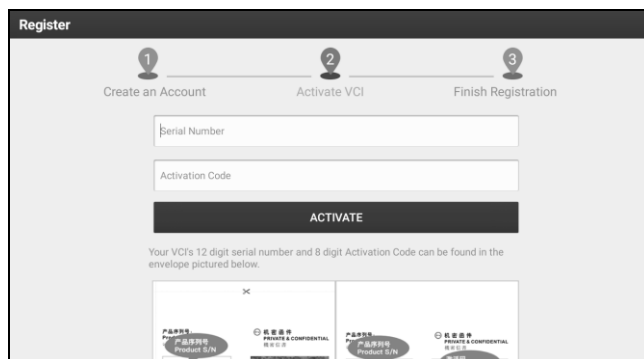

Input the 12-digit Product Serial Number and 8-digit Activation Code (can be obtained from the password envelope), and then tap **Activate**.

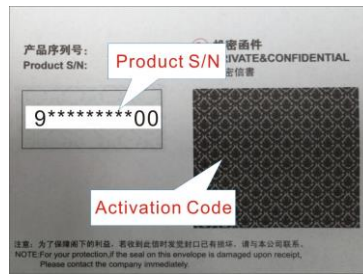

Tap **OK** to navigate to the update center to update all available software.

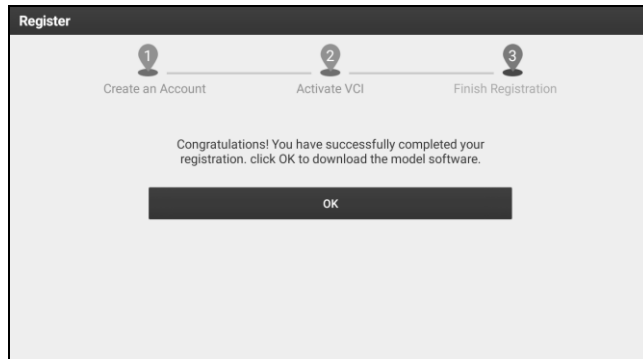

After the registration is successfully complete, the wireless communication between the tablet and the SmartLink C device is automatically established and user has no need to configure it again.

B. If you have registered to be a member, input your name and password, and then tap the **Login** button to enter the main menu screen directly.

*Note: The tablet has an auto-save function. Once the username and password are correctly entered, the system will automatically store it. After initial setup, it is no longer necessary to input the account information manually to log in.

C. If you have created a sub-account or bound an existing account to the tool, tap **Technician login** to login. For more details on sub-accounts, refer to Chapter 9.3.11.

D. If you forgot the password, tap **Retrieve password** and then follow on-screen instructions to set a new password.

3.2 Home Screen

It mainly includes the following items:

Name	Description
IMMO	Enable you to perform the anti-theft key matching function, so that the immobilizer control system on the car identifies and authorizes remote control keys to normally use the car.
IMMO PROG	<ul style="list-style-type: none"> • Read transponder data (including Mercedes Benz infrared smart key), and generate exclusive keys. • Read/write on-board EEPROM chip data, and read/write MCU/ECU chip data.
Key Programmer	Enable you to perform key programming operations, including

LAUNCH

	read/generate key transponder, detect frequency and set type of super chip & wireless remote, etc. It needs to work with specific key programmer (sold separately).
Intelligent Diagnose	<ul style="list-style-type: none">• Obtain vehicle data from the cloud server to perform quick test via reading VIN, to avoid various defects resulting from step-by-step menu selection.• Check the historical repair records online.
Remote Diagnose & SmartLink Diag.	Remote Diagnose: This option aims to help repair shops or technicians launch instant messaging and remote diagnosis, making the repair job getting fixed faster. SmartLink Diag.: The SmartLink system is powerful remote diagnostics solution developed by LAUNCH. The system consists of SmartLink C dongle, SmartLink Service Platform and SmartLink B dongle.
Local Diagnose	Diagnose a vehicle manually.
TPMS	Configure this tool as a professional TPMS (Tire Pressure Monitoring System) service tool. It needs to work with specific TSGUN device (sold separately) to perform all kinds of various TPMS functions.
ADAS	Perform ADAS (Advanced Driver Assistance System) calibration operations. It needs to work with specific ADAS calibration tool (sold separately).
Service function	It offers coding, reset, relearn and more service functions, to help vehicles get back to functional status after repair or replacement.
Feedback	Feedback the recent 20 diagnostic logs to us for issue analysis.
Mail	Subscribe some extra software or service functions that are not included in the diagnostic tool online.
Software Update	Update vehicle diagnostic software and APK.
Info Center	Include product information and repair data etc.
Diagnostic History	<ul style="list-style-type: none">• Access the diagnostic reports from the previously tested vehicles.• Resume the previous operation without starting from scratch.
Other Modules	Include user Info, toolbox and some frequently used built-in apps.

4 Connections

4.1 Preparation

1. Make sure that the ignition is turned off and vehicle battery voltage range is 9-14V or 18-30V.
2. Find DLC location.

For passenger cars, the DLC(Data Link Connector) is usually located 12 inches from the center of the instrument panel, under or around the driver's side for most vehicles. For some vehicles with special designs, the DLC location may vary. Refer to the following figure for location.

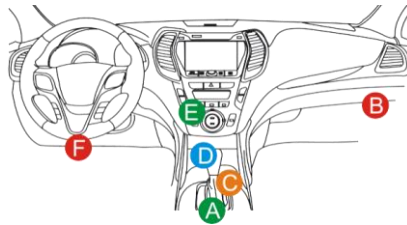

A. Opel, Volkswagen, Audi

B. Honda

C. Volkswagen

D. Opel, Volkswagen, Citroen

E. Changan

F. Hyundai, Daewoo, Kia, Honda, Toyota, Nissan, Mitsubishi, Renault, Opel, BMW, Mercedes-Benz, Mazda, Volkswagen, Audi, GM, Chrysler, Peugeot, Regal, Beijing Jeep, Citroen and other most popular models

If the DLC cannot be found, refer to the vehicle's service manual for the location.

For commercial vehicles, the DLC is always located in driver's cab.

3. Refer to Chapter 4.2 to make connection.
4. Turn the vehicle' ignition ON with engine OFF.
5. Now the tool is ready for diagnostics.

4.2 Vehicle Connection

The method used to connect the VCI device to a vehicle's DLC depends on the vehicle's configuration as follows:

For OBD II vehicles, use the included diagnostic cable (DB15F to HD15F data cable and HD15M to OBD16 adaptor) to connect the VCI to the vehicle's DLC port.

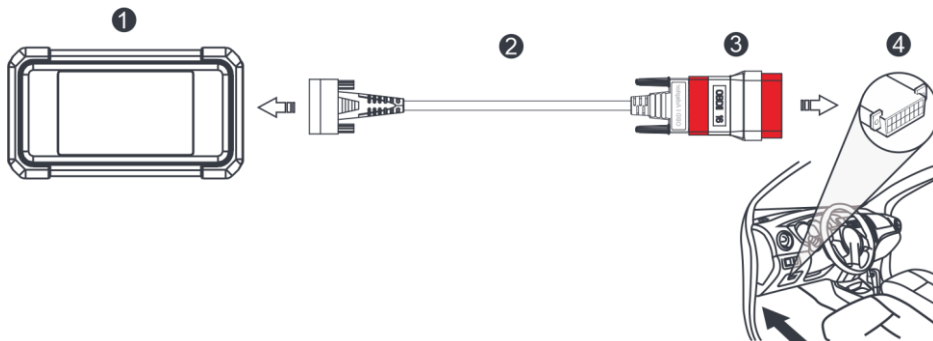

LAUNCH

1. VCI
2. DB15F to HD15F data cable
3. HD15F to OBD16 adaptor
4. Vehicle's DLC port

For non-OBDII vehicles, refer to the above figure to make connection.

1. Select the appropriate adaptor according to the vehicle's DLC port type (4).
2. Loosen the captive screws of the DB15F to HD15F data cable (2) and disconnect the HD15F to OBD16 adaptor (3) from the data cable.
3. Connect the data cable (2) with the target adaptor (sold separately) on the above figure and tighten the screws. Other steps shall also apply.

If you choose to perform vehicle diagnosis via data cable, connect one end of the data cable into the VCI, and the other end into the data I/O port of the tablet.

5 Key Immobilizer & Immobilizer Programming

An immobilizer is an anti-theft mechanism that prevents a vehicle's engine from starting unless the correct ignition key or other device is present. Most new vehicles have an immobilizer as standard equipment. An important advantage of this system is that it doesn't require the car owner to activate it since it operates automatically. An immobilizer is considered as providing much more effective anti-theft protection than an audible alarm alone.

As an anti-theft device, an immobilizer disables one of the systems needed to start a car's engine, usually the ignition or the fuel supply. This is accomplished by radio frequency identification between a transponder in the ignition key and a device called a radio frequency reader in the steering column. When the key is placed in the ignition, the transponder sends a signal with a unique identification code to the reader, which relays it to a receiver in the vehicle's computer control module. If the code is correct, the computer allows the fuel supply and ignition systems to operate and start the car. If the code is incorrect or absent, the computer disables the system, and the car will be unable to start until the correct key is placed in the ignition.

5.1 Key Immobilizer (IMMO)

This function enables you to perform the anti-theft key matching function, so that the immobilizer control system on the car identifies and authorizes remote control keys to normally use the car.

It needs to be performed in the following cases:

When the ignition switch key, ignition switch, combined instrument panel, ECU, BCM, or remote control battery is replaced.

5.1.1 Vehicle connection

- 1). For most vehicles, just use the included diagnostic cable to connect the VCI to the vehicle's DLC port.
- 2). For other vehicles (including but not limited to the Mercedes Benz, Volkswagen, BMW and Porsche), the X-PROG 3/X-PROG is required.

5.1.2 Immobilizer operations

Here we take the BMW for example to demonstrate how to perform the functions of key adding and all lost for BMW CAS4/CAS4+ Anti-theft system module.

- 1) Tap **IMMO** and select **BMW** to enter the software.

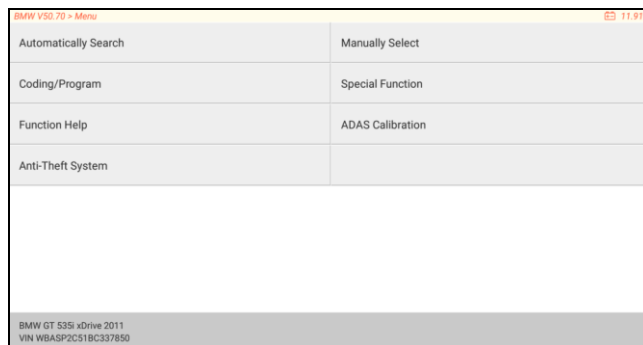

- 2) Tap **OK**.

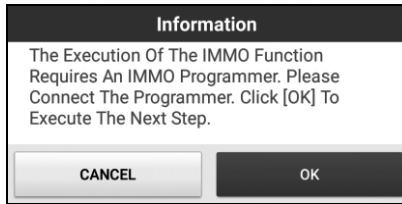

3) Enter the Anti-Theft System, follow the illustration below to connect the VCI, vehicle and X-PROG3/X-PROG (*needs to purchased separately) to perform the next step.

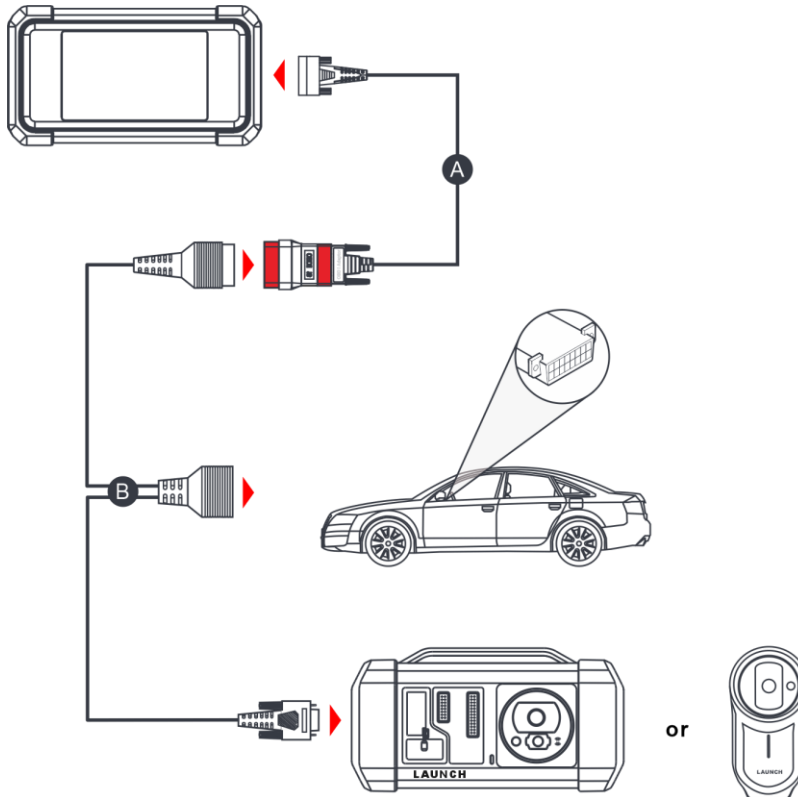

4) If you don't know the type of the Anti-Theft System, tap **Intelligent Mode** to enter.

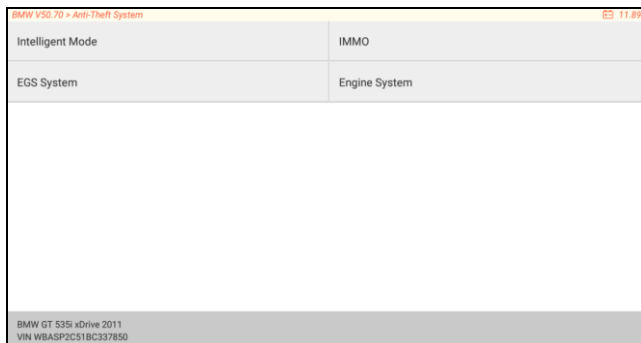

5) Tap CAS4/CAS4+ Anti-Theft System, the following screen will appear:

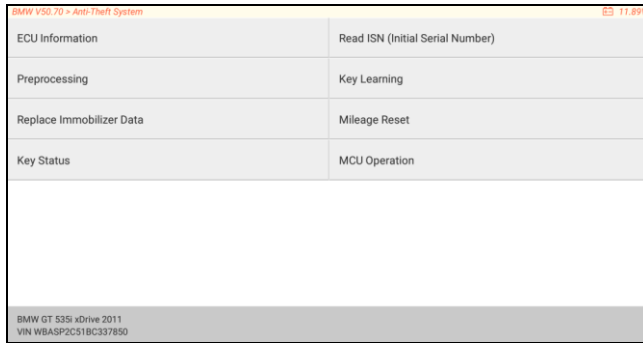

6) Tap **Preprocessing** to perform Read Anti-Theft data, Key Matching and more. If it has already been preprocessed, here you can perform the relevant functions. The ECU will be upgraded in this process, and files need to be downloaded online.

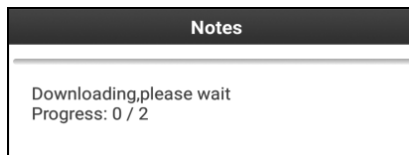

7) Make sure that vehicle power supply voltage is not lower than 13V and stable, and then tap **Yes** to start preprocessing.

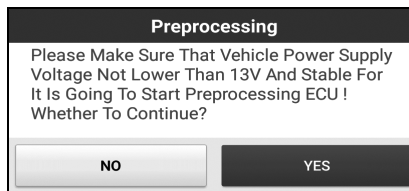

8) After preprocessing succeeded, tap **OK**.

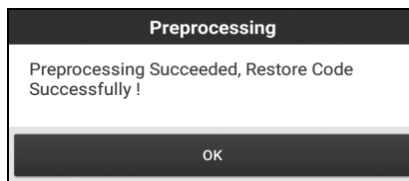

9) Return to the function menu and tap **Key Learning**.

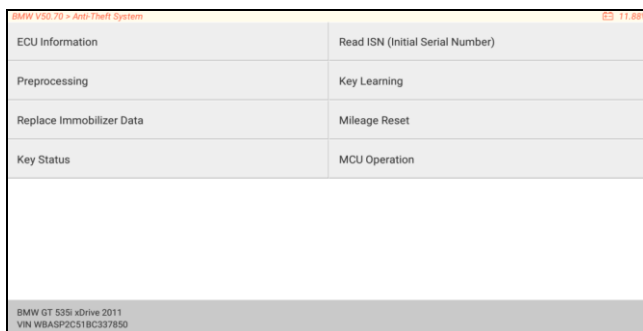

10) After the key information successfully read, select the unused key position and tap **Key Generated By Ignition Switch**.

Key Position	Key ID	Key Status
Key 1	FFFFFFF	Unused
Key 2	A281AA32	Used
Key 3	FFFFFFF	Unused
Key 4	FFFFFFF	Unused
Key 5	FFFFFFF	Unused
Key 6	FFFFFFF	Unused
Key 7	FFFFFFF	Unused

Key Generated By Ignition Switch Key Generated By Programmer Erase Key 1

BMW GT 535i xDrive 2011
VIN WBASP2C518C337850

11) Read and display the password, and tap **OK**.

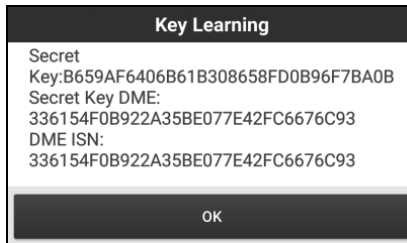

12) Place a new key close to vehicle coil, tap **OK**, and wait for the key to generate.

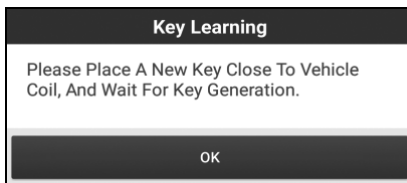

13) After the dealer key is successfully generated, please try to start the vehicle.

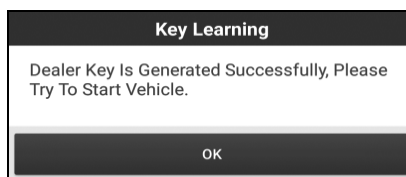

14) Now the key matching is finished and the new key is ready for use.



5.2 Immobilizer Programming (IMMO PROG)

The X-PROG 3 is required when performing this operation.

It has the following functions:

- 1). Read transponder data (including Mercedes Benz infrared smart key), and generate exclusive keys.
- 2). Read/write on-board EEPROM chip data, and read/write MCU/ECU chip data.

For more detailed operations, refer to the User Manual of the X-PROG 3.

5.3 Key Programmer

This module can identify car key chips and generate various types of chip models from super remotes, read remote control frequency of car keys, and generate remote control devices for different car models from various types of super remotes.

It needs to work with the specific compatible Key Programmer (sold separately).

Refer to the User Manual of the Key Programmer for detailed operations.

6 Diagnosis

6.1 Intelligent Diagnose

Through simple wireless communication between the tablet and VCI, you can easily get the VIN (Vehicle Identification Number) information of the currently identified vehicle. Once the VIN is successfully identified, the system will retrieve it from the remote server and then guide you to vehicle information page without performing the step-by-step manual menu selection.

The vehicle information page lists all historical diagnostic records of the vehicle, which lets the technician have a total command of the vehicle faults. In addition, a quick dial to Local Diagnose and diagnostic function are also available on this page for reducing the roundabout time and increasing productivity.

*Notes: A stable network connection is required for this function. Before using this function, please make sure the VCI is properly connected to the vehicle's DLC port. For detailed connection, see Chapter 4.2.

Follow the steps below to proceed.

1. Tap **Intelligent Diagnose** to start pairing with the VCI.
 2. After pairing is complete, the tablet starts reading the vehicle VIN.
- A. If the VIN can be found from the remote server database, the following screen will appear:

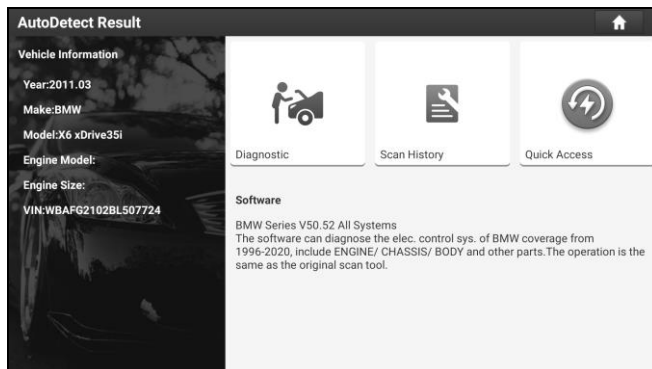

- Tap **Diagnostic** to start a new diagnostic session.
- Tap **Scan History** to view its historical repair record. If there are records available, it will be listed on the screen in sequence of date. If no records exist, the screen will show *No Record*.
- To perform other functions, tap **Quick access** to directly go to the diagnostic function selection screen. Choose the desired one to start a new diagnostic session.

B. If the tablet failed to access the VIN information, the following screen will appear:

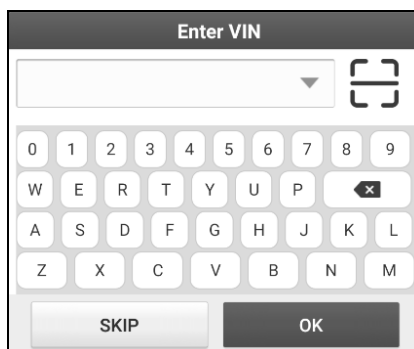





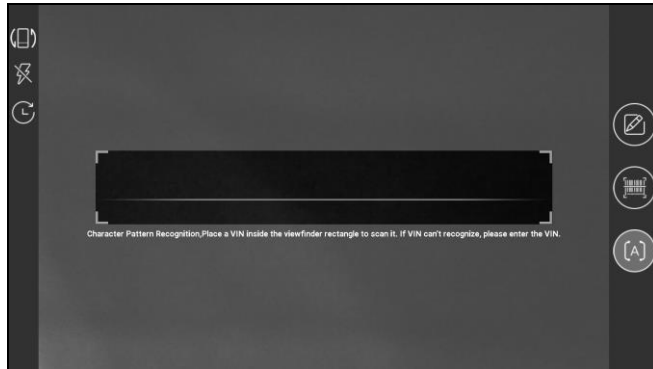

LAUNCH

- Tap the input field to directly, tap **OK**. If the VIN exists on the remote server, the system will enter the diagnostic function selection screen.
- Tap  to launch the VIN recognition module.



Place the VIN inside the viewfinder rectangle to scan it. The most recognizable location for this number is in the top left corner on the vehicle's dashboard. Other locations include the driver's door or post, and the firewall under the hood.

- Tap  to switch the display mode of the screen.
- Tap  to turn the camera flash on.
- Tap  to choose it from the record list if the VIN of the vehicle has been scanned before.
- Tap  to input the VIN manually if the tablet has failed to decode the VIN of the vehicle.
- Tap  to scan the VIN barcode.
- Tap  to scan the VIN character.

*Note: In general, vehicle identification numbers are standardized - all contain 17 characters. VIN characters may be capital letters A through Z and numbers 1 through 0; however, the letters I, O and Q are never used in order to avoid mistakes of misreading. No signs or spaces are allowed in the VIN.

After scanning, the screen automatically displays the result.

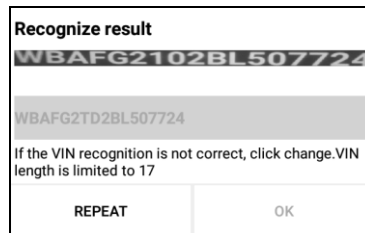

If the VIN scanned is incorrect, tap the result field to modify it and then tap **OK**. To scan it again, tap **REPEAT**. If the VIN exists on the remote server, the system will enter the diagnostic function selection screen.

6.2 Local Diagnose

Tap **Local Diagnose** to enter the vehicle selection page.

2 approaches are provided for you to access the vehicle diagnostic software. Choose any one of the following ways:

LAUNCH

1. VINSCAN enables you to access it more quickly. In this case, Camera Scan and Enter VIN are available.

Camera Scan: Scan the VIN automatically.

Enter VIN: Input the vehicle VIN manually.

If the tablet successfully identifies the vehicle model, it will directly enter the diagnostic function selection menu.

2. Tap a corresponding diagnostic software logo, and then follow the on-screen instruction to access the diagnostic software.

Take Demo (V15.21) as an example to demonstrate how to diagnose a vehicle.

1). Select diagnostic software version: Tap the **DEMO** to go to Step 2.



On-screen Buttons:

Vehicle Coverage: Tap to view the vehicle models that the current diagnostic software covers.



What's new: Tap to view the optimized items and enhancements.

Introduction: Tap to check the software function list.

Note: Tap to read some precautions on using the current diagnostic software.

OK: Tap it to go to next step.

The diagnostics toolbar contains a number of buttons that enable various procedures. It is displayed at the top of the vehicle diagnostic screen throughout the whole diagnostic session. Refer to the table below for a brief description of the functions of the diagnostics toolbar buttons:

	Return to the home screen.
	Tap to print the selected screenshots out via external printer. The printer needs to be configured separately. For details on printer setting, refer to Chapter 9.3.11.
	Exit the diagnostic application.

2). Select vehicle model: Here we take **Ford** for example to demonstrate how to diagnose a vehicle.

3). Read vehicle information: After reading the vehicle information, double check if the vehicle information is correct or not. If yes, tap **Yes** to continue.

4). Select test item: Select the desired test item to proceed.

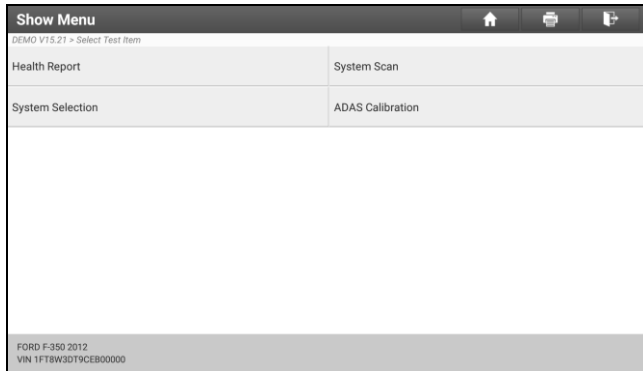

5). Turn the ignition key to ON: Set the ignition switch to on.

6.2.1 Health report (Quick Test)

This function varies from vehicle to vehicle. It enables you to quickly access all the electronic control units of the vehicle and generate a detailed report about vehicle health.

On the test item selection screen, tap **Health Report** and turn on the ignition switch, the system will start scanning the ECUs. Once the scanning process is complete, the following screen will appear:



The tested system with fault code appears in red and the system with OK displays in green (normally).

*Note: Diagnostic Trouble Codes or Fault Codes can be used to identify which engine systems or components that are malfunctioning. Never replace a part based only on the DTC definition. Retrieving and using DTCs for troubleshooting vehicle operation is only one part of an overall diagnostic strategy. Follow testing procedures (in vehicle’s service manual), instructions and flowcharts to confirm the locations of the problem.

On-screen Buttons:

Enter: Tap to enter the diagnostic function selection screen.

 **(Search):** Highlight certain diagnostic trouble code and tap it to retrieve it in the search engine.

Report: Tap to save the diagnostic result as a health report.

Report Information

Report Type
Pre-Repair

Vehicle Information
FORD F-350
2012 22100 miles
1FT8W3DT9CEB00000 License #:

Report Info
FORD_1FT8W3DT9CEB00000_AllSystemDTC_20200624010901

Notes:

SKIP OK

*Note: Diagnostic report is classified into three categories: Pre-Repair report, Post-Repair report and Diagnostic Scan. To facilitate the comparison of the pre-repair and post-repair reports and get accurate test result, please make sure you saved the right type of the diagnostic report. To save the report as a common diagnostic report, select **Diagnostic Scan**.

More Information

Shop Name LAUNCH STORE Telephone 7558888888

Address line1 shenzhen Email cnlaunch@qq.com

Address line2 longhua Technician Name Add

City shenzhen Customer Name Customer Name

State china Zip Code 23100 Country Armenia

SKIP OK

*Note: By default, the workshop information is blank. You can configure and revise it from Other Modules -> Settings -> Shop Information. After you configured the information, it will be automatically generated every time the diagnostic report is saved. All vehicle and workshop information will be appended as a tag on the diagnostic report, which allows you to easily retrieve the desired report while performing Filter function of Diagnostic Report.

On the report details screen, tap **Save** to save it. All diagnostic reports are saved in **Other Modules -> User Info -> My Report -> Health Report**.

Help: Tap to view the help information of the selected DTC item.

Compare Results: Tap to select the pre-repair report to compare. By comparison of the pre- and post-repair reports, you can easily identify which DTCs are cleared and which remain unfixed.

Compare Results		
DEMO V15.21 - Health Report		
DTC	Post	Pre
PCM (Powertrain Control Module)		
P0401 EGR Valve A Flow Insufficient Detected	Cleared	Found
P1291 Injector High Side Short To GND Or VBATT (Bank1)	Cleared	Found
P2073 Manifold Absolute Pressure/Mass Air Flow-Throttle correlation at idle	Cleared	Found

*Note: Before performing this function, please make sure that: 1) You have saved a pre-repair report of the currently tested vehicle; and 2) You have already made some repairs and service and cleared the DTCs after the pre-repair reported is generated. Otherwise, no differences exist between the pre- and post- repair reports.

Clear DTCs: Tap to clear the existing diagnostic trouble codes.

*Note: Clearing DTCs does not fix the problem(s) that caused the code(s) to be set. If proper repairs to correct the problem that caused the code(s) to be set are not made, the code(s) will appear again and the check engine light will illuminate as soon as the problem that cause the DTC to set manifests itself.

6.2.2 System scan

This option allows you to quickly scan which systems are installed on the vehicle.

6.2.3 System selection

This option allows you to manually select the test system and function step by step.

On the test item selection screen, tap **System Selection**, the screen displays as follows:

Show Menu	
DEMO V15.21 - System Selection	
PCM (Powertrain Control Module)	TCM(Transmission Control Module)
ABS(Anti-lock Braking System)	RCM (Restraint Control Module)
BCM(Body Control Module)	IMMO(Immobilizer)
APIM (Accessory Protocol Interface Module)	PAM (Parking Assist Module)
ICM1 (Information Center Module)	DDM (Driver Door Module)
DSM (Driver Seat Module)	DSP (Digital Signal Processor)
IPC (Instrument Panel Control Module)	FCIM (Front Controls Interface Module)
FORD F-350 2012 VIN 1FT8W3D19CEB00000	

Tap the target system (take **ECM** for example) to navigate to the diagnostic function selection screen.

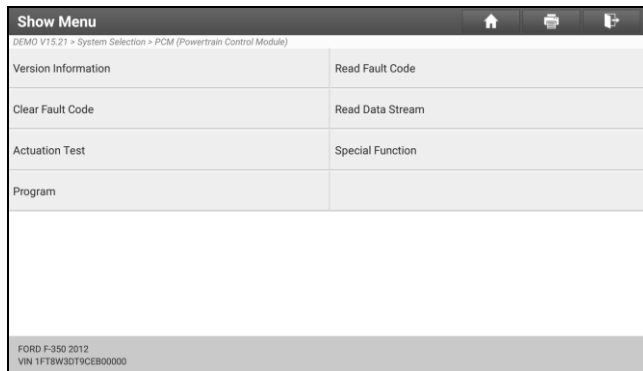

*Note: Different vehicle has different diagnostic menus.

A. Version Information

This function is used to read the version information of system mode, vehicle VIN, software and ECU.

B. Read Fault Code

This function displays the detailed information of DTC records retrieved from the vehicle's control system.

On the diagnostic function selection screen, tap **Read Fault Code**, the screen will display the diagnostic result.

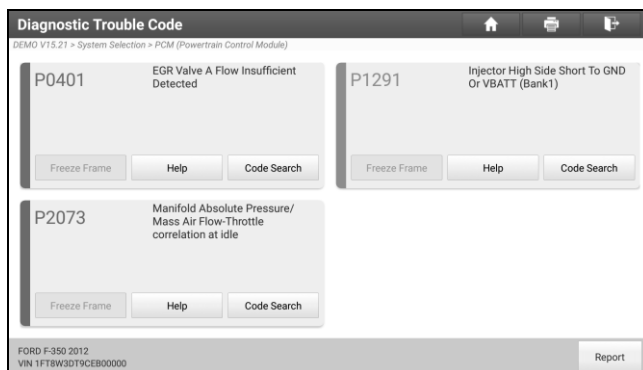

On-screen Buttons:

Freeze Frame: Tap it to view the snapshot of critical parameter values at the time the DTC is set.

Help: Tap to view the help information.

Code Search: Tap to search for more information about the current DTC online.

Report: Tap to save the current data in text format. All reports are saved in **Other Modules -> User Info -> My Report -> Health Reports**. For details on report operations, please refer to Chapter 9.3.1.

C. Clear Fault Code

This option can erase the codes from the vehicle. Before the operation, please make sure the vehicle's ignition key is in the ON position with the engine off.

*Note: After clearing, you should retrieve trouble codes once more or turn ignition on and retrieve codes again. If there are still some trouble codes in the system, please troubleshoot the code using a factory diagnosis guide, then clear the code and recheck.

D. Read Data Stream

This option retrieves and displays live data and parameters from the vehicle’s ECU.

Caution: If you must drive the vehicle in order to perform a troubleshooting procedure, ALWAYS have a second person help you. Trying to drive and operate the diagnostic tool at the same time is dangerous, and could cause a serious traffic accident.

On the diagnostic function selection screen, tap **Read Data Stream**, the following screen will appear.

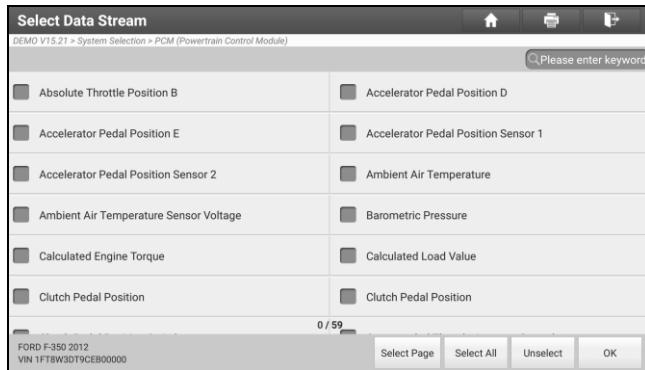

On-screen Buttons:

Select Page: Tap to select all items of the current page.

Select All: Tap to select all items. To select certain data stream item, just check the box before the item name.

Unselect: Tap to deselect all data stream items.

OK: Tap to confirm and jump to the next step.

After selecting the desired items, tap **OK** to enter the data stream reading page.

Name	Value	Standard Range	English	Metric
Absolute Throttle Position B	14.12	0 - 100	%	
Accelerator Pedal Position D	7.06	0 - 100	%	
Accelerator Pedal Position E	24.71	0 - 100	%	
Accelerator Pedal Position Sensor 1	1.04	0 - 5	V	
Accelerator Pedal Position Sensor 2	0.53	0 - 5	V	
Ambient Air Temperature	21	-40 - 215	degree C	

***Notes:**

1. If the value of the data stream item is out of the range of the standard (reference) value, the whole line will display in red. If it complies with the reference value, it displays in blue (normal mode).
2. The indicator 1/X shown on the bottom of the screen stands for the current page/total page number. Swipe the screen from the right/left to advance/return to the next/previous page.

There are 3 types of display modes available for data viewing, allowing you to view various types of parameters in the most suitable way.

- Value – this is the default mode which displays the parameters in texts and shows in list format.
- Graph – displays the parameters in waveform graphs.

LAUNCH

- Combine – this option is mostly used in graph merge status for data comparison. In this case, different items are marked in different colors.

On-screen Buttons:

 **Graph(Single):** Tap to view the parameter in waveform graph.

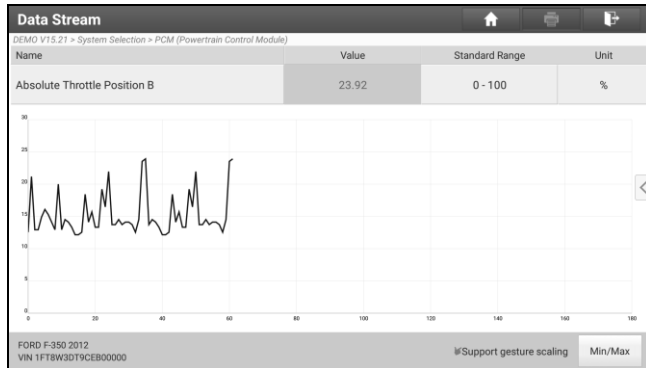

Graph: Tap to view the parameters in waveform graphs.

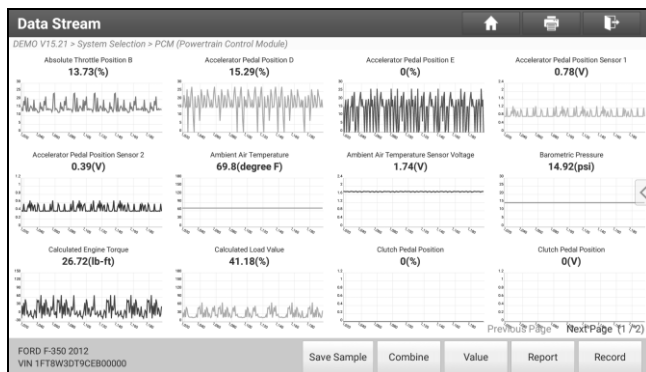

Compare Sample: Tap it to select the sample data stream file, the values you customized and saved in process of data stream sampling will be imported into the **Standard Range** column for your comparison.

Note: Before executing this function, you have to sample the values of data stream items and save it as a sample data stream file.

Report: To save the current data in text format. All reports are saved in **Other Modules -> User Info -> My Report -> Health Reports**.

Record: Tap to start recording diagnostic data. Recorded live data can serve as valuable information to help you in troubleshooting of vehicle problems. All recorded files are stored in **Other Modules -> User Info -> My Report -> Recorded Data**.

Help: Tap to view the help information.

Save Sample: This item enables you to customize the standard range of live data stream items and save it as sample file. Each time you run the data stream items, you can call out the corresponding sample data to overwrite the current standard range.

Tap it to start recording the sample data (Note: Only data stream items with units will be recorded). Once recording is complete, tap  to stop it and navigate to the data modification screen.

Confirm Sample DS			
DEMO Y15 21 > System Selection > PCM (Powertrain Control Module)			
Name	Min Value	Max Value	Unit
Absolute Throttle Position B	12.55	23.92	%
Accelerator Pedal Position D	0.0	27.84	%
Accelerator Pedal Position E	0.0	26.67	%
Accelerator Pedal Position Sensor 1	0.78	1.28	V
Accelerator Pedal Position Sensor 2	0.39	0.65	V
Ambient Air Temperature	21.0	21.0	degree C

FORD F-350 2012
VIN 1FT8W3D19CEB00000

Save

Tap the value to change it. After modifying all desired items, tap **Save** to save it. All data stream files are stored in **Other Modules -> User Info -> Sample**.

E. Actuation Test

This option is used to access vehicle-specific subsystem and component tests. Available test vary by vehicle manufacturer, year, and model.

During the actuation test, the tablet outputs commands to the ECU in order to drive the actuators, and then determines the integrity of the system or parts by reading the ECU data, or by monitoring the operation of the actuators, such as switching a injector between two operating states.

6.2.4 ADAS calibration

This function enables users to perform ADAS calibration operations. The ADAS calibration software is disabled by default. Before using this function, users must activate it using the ADAS Activation Card.

6.3 Remote Diagnose

6.3.1 SmartLink Super Remote Diagnostics

SmartLink is a newly developed powerful service system dedicated to remote vehicle diagnosis and service. In the SmartLink ecology system, if a technician (SmartLink C) does not have time to puzzle through a touch vehicle problem, he can seek a trusted second opinion or additional expertise on various vehicle issues from remote master technicians or repair shops (SmartLink B). SmartLink B enables the shop owner to greatly increase customer’s retention and boost shop revenue by providing professional technical assistance service.

It mainly consists of the following parts:

- **SmartLink Service Platform** – It can be accessed from the **SmartLink** module of the diagnostic tablet. There are two modules available on the link service platform: **Common user** (for SmartLink C) and **Service provider** (for SmartLink B).
- **SmartLink C (Customer) - SmartLink Service Subscriber**. In the SmartLink system, the SmartLink C needs to perform the following operations.
 - 1). Launch Service Link Platform: Binds SmartLink C dongles and submits remote repair orders.
 - 2). SmartLink C Dongle: Connects to the vehicle’s DLC port for collecting the vehicle data and sends it to the remote SmartLink B.

It supports remote diagnostic services for vehicles that meet CAN / CAN FD / J2534 vehicle diagnostic standards.

LAUNCH

- **SmartLink B (Business) - SmartLink Service Provider.** In the SmartLink system, the SmartLink B needs to perform the following operations.
 - 1). Launch Service Link Platform: Binds SmartLink B dongles and accepts orders from SmartLink C.
 - If the SmartLink B dongle works with the LAUNCH-specific diagnostic tool equipped with SmartLink module, tap **SmartLink** to add the SmartLink B device and accepts orders on the diagnostic tool.
 - If the SmartLink B dongle works with the third-party diagnostic tool, open the browser and visit SmartLink Service Platform website <http://smartlink.x431.com> (web client) to add the SmartLink B device and accepts orders in the browser.
 - 2). SmartLink B Dongle: After accepting the orders, it can work with the compatible diagnostic tool to perform diagnosis of the vehicle connected to the SmartLink C dongle.

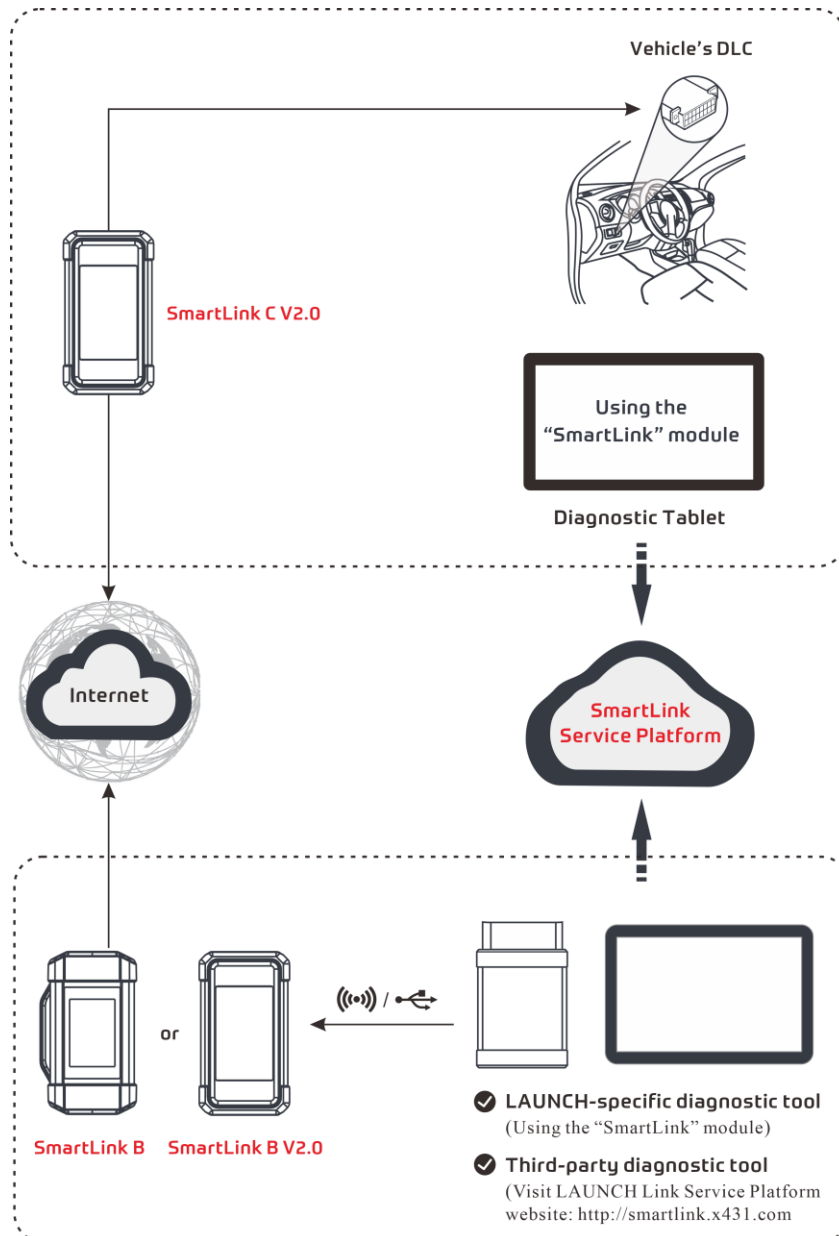

LAUNCH

For more detailed operations, refer to the User Manual integrated in the SmartLink Platform.

6.3.2 X431 Remote Diagnostics

This option aims to help repair shops or technicians launch instant messaging and remote diagnosis, making the repair job getting fixed faster.

Tap **Remote Diagnose** on the Job menu, the screen appears blank by default.

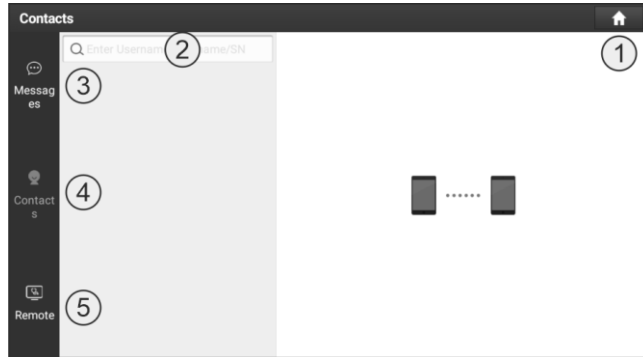

1	Home button	Tap it to navigate to the Job menu screen.
2	Search bar	Directly input the registered username of the tool to start searching, and then tap the desired one to add it into your friend list.
3	Messages tab	Once an incoming message reaches, a red dot will appear on the upper right corner of the tab.
4	Contacts tab	Tap to enter the friend list.
5	Remote switch	Tap to slide the switch to ON, the tool keeps online and becomes accessible on the web client. In this case, inform the technician of your product S/N, and he/she will control your device remotely.

1. Adding Friends

Tap **Contacts**. By default it appears blank. Input the partner's username and tap **Search** to start searching.

The partner must be the users who have registered specific diagnostic tools. They may be workshop / technician / golo users.

Once the result matches the keyword, the following screen will appear:

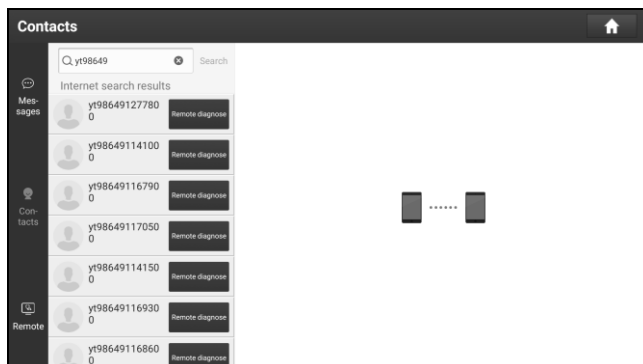

LAUNCH

Here you can tap **Remote Diagnose** to launch remote diagnostics directly or choose to add the partner into the Contacts list.

Tap the desired name from the list, the following screen will appear:

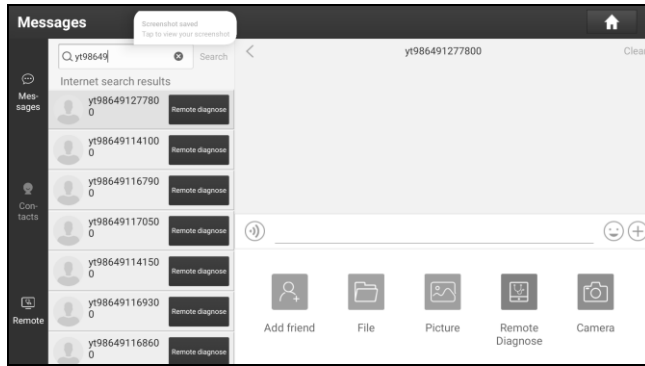

Tap **Add friend** to send your request.

Once the partner receives the request, a beep will sound. Tap **Messages**:

- Once the partner agreed your request, he/she will automatically be listed in the Contacts tab.
- If a technician sent you a friend request, tap **Agree** and his/her name will appear in the Contacts list. Or tap **Ignore** to ignore this request.

2. Start Instant Messaging

The I/M (Instant Messaging) function is open to all users who had the diagnostic tool equipped with this module.

After adding your friends, tap the desired one's photo to enter the following screen:

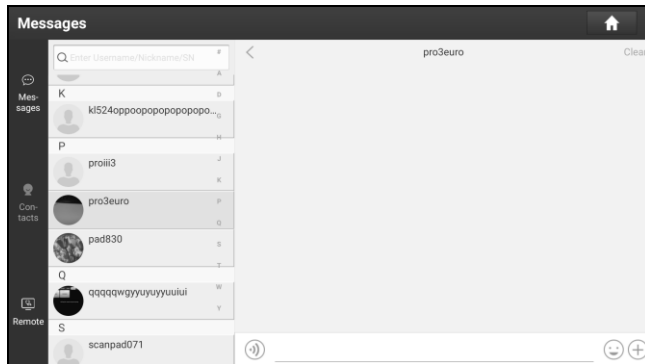

Tap the input field and use the on-screen keyboard to send the text message.

Tap  to send voice message.

Tap  to send emoji.

Tap  to call out more function options.

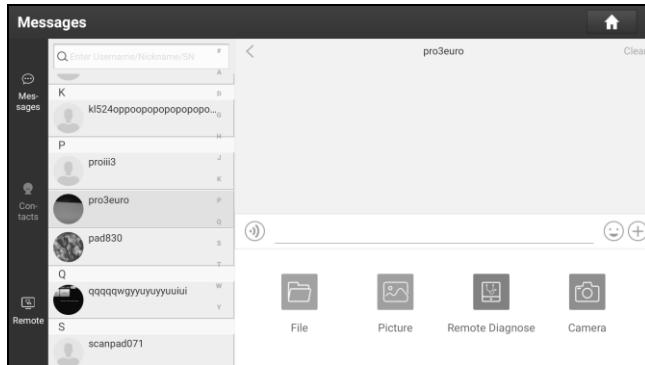

File: Choose diagnostic reports or local files to send.

Picture: Choose screenshots or pictures to send.

Remote Diagnose: To start a remote diagnostic session.

Camera: Open camera to take pictures.

Tap **Clear** to delete all the partner’s dialog logs.

3. Launch Remote Diagnosis (Scanner-To-Scanner)

The tool is allowed to initiate remote diagnosis with other diagnostic tools, which are equipped with this module.

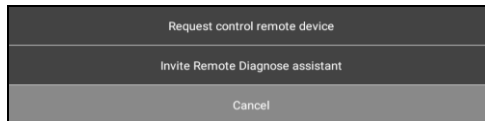

On the function option selection screen, tap **Remote Diagnostic**, the following pull-down menu will appear:



These options are defined as follows:

Actions	Results
Request control remote device	Request to control the partner’s device remotely to help him diagnose the vehicle. *Note: In process of remote diagnosis, tap the  button to send a voice message. Once vehicle diagnosis is complete, a report will be created. Input your comments on this report, and then tap Send Report to send it to the partner.

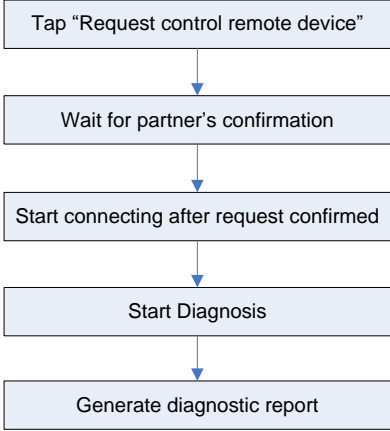
LAUNCH

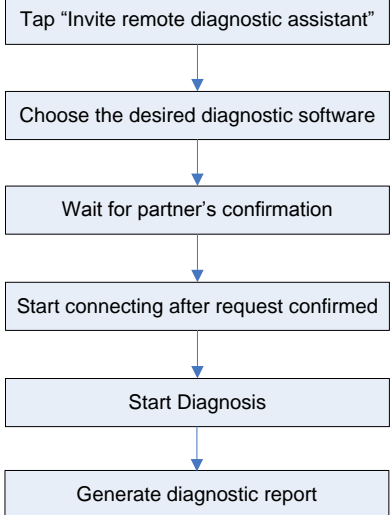
	 <pre>graph TD; A[Tap "Request control remote device"] --> B[Wait for partner's confirmation]; B --> C[Start connecting after request confirmed]; C --> D[Start Diagnosis]; D --> E[Generate diagnostic report];</pre>
Invite remote diagnostic assistant	<p>Use this option to invite a technician to perform a remote control on your tool.</p> <p> Note: Once you received the report from the partner, tap View Report to view details. All diagnostic reports are saved under Other Modules -> User Info -> My Report -> Remote Report.</p>  <pre>graph TD; A[Tap "Invite remote diagnostic assistant"] --> B[Choose the desired diagnostic software]; B --> C[Wait for partner's confirmation]; C --> D[Start connecting after request confirmed]; D --> E[Start Diagnosis]; E --> F[Generate diagnostic report];</pre>
Cancel	To cancel this operation.

4. Launch Remote Diagnosis (Scanner-To-PC)

User also can ask for remote control from a PC client technician.

Tap **Remote**, the following screen will appear:

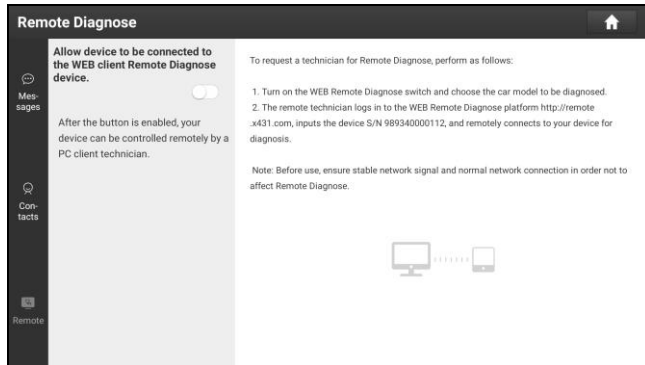

1. Slide the switch to ON so that the partner can connect to your scanner.
2. Notify the partner to visit <http://remote.x431.com> until the following screen appears on the PC.

Note: Before processing remote diagnosis, please make sure the scanner is properly connected to the vehicle.

3. After the partner successfully logs in (using his own official technician account and password), the following screen will appear.

4. Tell the partner to enter the Serial Number of your scanner, and then tap **Start remote diagnosis** to control your scanner remotely.

In process of remote diagnosis, please note the following things:

1) You are not suggested to execute any actions.

2) The partner is not allowed to save any diagnostic reports or records on your scanner.

Once the session is complete, a remote diagnostic report will be automatically generated.

6.4 Diagnostic History

This function enables users to directly get access to the previously tested vehicle's diagnostic records in details, so users can resume from the last operation, without starting from scratch.

Tap **Diagnostic History** on the Job menu screen, all diagnostic records will be listed on the screen in date sequence.

6.5 Feedback

This function enables you to send the feedback of your diagnostic problems to us for further analysis and troubleshooting.

There are 3 options:

1). Feedback: To send a tested vehicle diagnostic feedback.

2). History: To view all diagnostic feedback records.

3). Offline list: To view all diagnostic logs that have failed to be submitted, which will be uploaded again to the remote server automatically once the tablet gets the stable network.

7 Service (Reset) Function

It offers coding, reset, relearn and more service functions, to help vehicles get back to functional status after repair or replacement. Available tests vary by vehicle manufacturer, year, and model.

Due to continuing improvements, the available service functions are subject to change at any time. To enjoy more service functions, you are suggested to check for updates on a regular basis.

8 Software Update

This module enables you to update the diagnostic software & App and frequently used software.

8.1 Update Diagnostic Software & APP

Go to **Software Update** on the Job Menu and tap the **Car model** tab.

The **Car model** tab displays a list of vehicle diagnostic software.

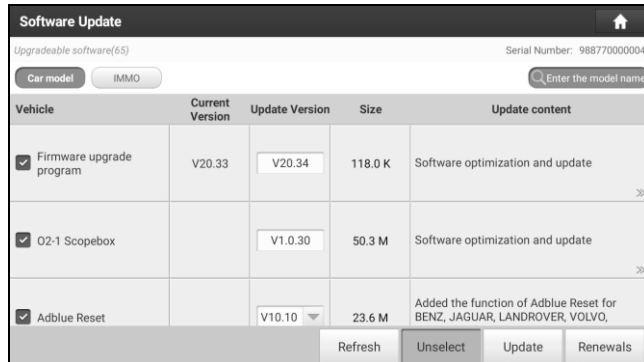

Tap **Update** to start downloading. Once download is finished, the software packages will be installed automatically.

8.2 Update IMMO&IMMO PROG Software

If the user only intends to update the IMMO&IMMO PROG software, go to Software Update and tap the **IMMO** tab.

Tap **Update** to start downloading. Once download is finished, the software packages will be installed automatically.

8.3 Renew Subscription

If the software subscription is due or expires, the system will prompt you to renew your subscription.

Tap **Renewal** to open the Mall, and then follow the on-screen prompts to finish the subscription.

9 ADAS (Calibration)

This module enables you to effectively and accurately calibrate a wide range of camera-based & radar-based driver assistance systems, e.g. the front camera for the lane departure warning system, the radar sensor for the ACC (Adaptive Cruise Control) or the camera for adaptive headlights. It needs to work with the specific ADAS calibration tool (sold separately).

For more details, please refer to the User Manual included with the module.

10 TPMS

This module allows you to configure the tablet as TPMS activation & diagnostic tool, which provides the ability to trigger TPMS sensor, program TPMS sensor, perform the relearning procedure. It needs to work with the compatible TSGUN device (sold separately).

For more details, please refer to the User Manual included with the module.

11 Other Modules

11.1 Common Apps

11.1.1 Vehicle Coverage

This option is used to check the vehicle models that the tools covers.

11.1.2 User Info

This function allows users to manage personal information and VCI.

1. My Report

This option is used to view, delete or share the saved reports.

Tap **Report**, there are total 3 options available.

In case the DTC result is saved on Read Trouble Code page, the files will be listed under **Health Reports** tab.

If user records the running parameters while reading data stream, the tablet will save the file which appears under **Recorded Data** tab.

Remote Reports lists all diagnostic reports generated in process of remote diagnosis.

2. VCI

This option allows you to manage all your activated VCI devices.

If several VCI devices are activated on this tool, a list of VCIs will be displayed on the screen. Once you choose the VCI that belongs to other account, you have to log out, and then input the right account to continue.

3. Activate VCI

This item lets you activate the VCI device in case you ignore the Activate VCI step in process of the product sign-up.

Input the Serial Number and Activation Code, and then tap **Activate** to activate it.

4. Fix Connector Firmware/System

Use this item to upgrade and fix VCI firmware/system. During fixing, please do not cut power or switch to other interfaces.

5. ADAS equipment selection

This feature allows you to download and check updates for vehicle calibration files of the corresponding ADAS calibration equipment.

6. Sample

This feature allows you to manage the recorded data stream sample files.

7. Vehicle Voltage

This item performs a check of the vehicle's battery to ensure the system is operating within acceptable limits.

8. My Order

This item allows you to check the status of all your orders.

9. Subscription Renewal Card

This item is used to check the status of the subscription renewal card.

10. Renault SGW

This feature is used to check the status and usage history of connection card (for accessing Renault Serving Gateway).

*Note: User needs to purchase the connection card from the local dealer separately.

11. Profile

Use this item to view and configure personal information.

12. Change Password

This item allows you to modify your login password.

13. Settings

It enables you to make some application settings and view software version information etc.

1). Units of measurement

It is designed to configure the measurement unit. Metric System and English System are available.

2). Shop information

This option lets you define your print information. It mainly includes Workshop, Address, Telephone, Fax and License Plate.

Once you saved the print information, it will be entered automatically in the "Add Information" box every time you save the diagnostic report.

3). Printer set

This option is designed to establish a wireless connection between the tablet and the Wi-Fi printer (sold separately) while performing printing operations.

The App is compatible with the LAUNCH Wi-Fi Printer (sold separately) and System (external printer).

For LAUNCH Wi-Fi printer, refer to the user manual included with the printer to configure it.

For other Wi-Fi printers,

Before printing, make sure the following conditions are met:

- The Wi-Fi printer is powered on and working normally.
- The print service plug-in associated with the printer is already installed on the tablet (Go to Google Play or use the Browser to download and install it).

Follow the steps below to proceed:

1. Set the default printer as **System**.
2. Go to **Other Modules -> Built-in apps -> Tablet Settings -> WLAN**, set the WLAN switch to Off.
3. On the report details page, tap .



4. Touch ▼ next to **Select a printer** on the upper left corner of the screen.
5. Select **All Printers -> Add printer** and enable the installed printer service, the system starts searching for all available Wi-Fi printers of the brand.

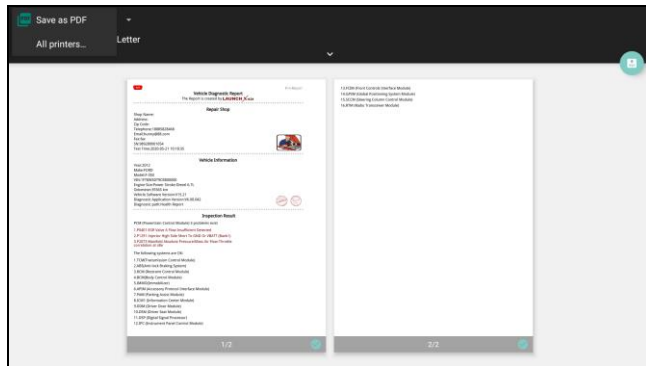

6. Select the desired Wi-Fi printer from the list. If the chosen Wi-Fi printer hotspot is open, the tablet can connect it directly. If it is encrypted, a password may be required. Refer to the Wi-Fi printer user manual to get the default password.
7. Now the printer is ready for printing.
8. Alternatively, you can also choose **Save as PDF** to save the current diagnostic report as a PDF file for later printing.

4). Clear cache

This item is used to clear the App cache.

5). About

The software version information and disclaimer are included.

6). Diagnostic software auto update

This option is used to set whether automatic update function is ON.

7). Device account management

This option is used to manage the sub-accounts. The added sub-account allows the VCI connector to be used by different users to log in the tool, which is convenient for multiple VCIs to perform diagnostic service at the same time.

The newly added sub-account has a one-year validity period. After the expiration, the VCI bound to the sub-account cannot be used and the sub-account will no longer enjoy the rights and interests of the main

account. The main account can modify the validity period of the sub-account.

There are two types of sub-accounts: one is an existing account and the other is a newly created account. The main account has the functions of adding and removing sub-accounts, the sub-account can also be unbound from the main account.

Tap **Device account management**, the following screen will appear:

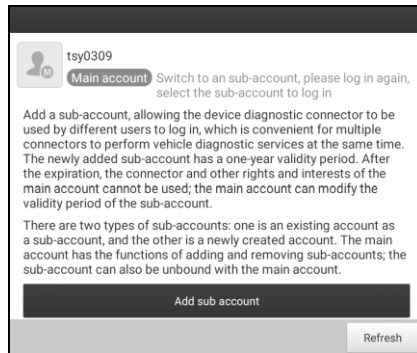

Tap **Add sub account**,

- If you already have an account, please enter the user name and password. After inputting, tap **Add Immediately** to add it as a sub-account.
- If you have not registered any account, tap **Create sub user** to create a sub-account.

After adding the sub-account, tap **Remove** to unbind it from the main account. To revise the validity period, tap **Change**.

8). Login/Log out

To logout the current user ID, tap **Log Out**.

To login the system again, tap **Login**.

14. Diagnostic Software Clear

This item allows you to hide/clear the diagnostic software that is not frequently used.

*Note: Removing software may completely delete the software from the tablet. If some software is not used and the tablet runs out of space, you can use this feature to remove it. To re-download it, go to **Software Update -> All Software**.

11.1.3 Toolbox

It includes some add-on modules, which can extend the functionalities of the diagnostic tool. Each module consists of two parts: hardware and app. These modules cannot work properly on the tablet, which need to work with the specific compatible hardware (sold separately).

Due to continuing improvements, the available add-on modules are subject to change at any time. To enjoy more functions, you are suggested to check for updates on a regular basis.

11.2 Bulit-in Apps

This module integrates some Android's system apps for quick dial.

11.2.1 Tablet Settings

This module allows you to make some Android's system settings.

11.2.2 TeamViewer QS

This function enables you to receive remote support from technician fellows, colleagues or friends by allowing them to control your tablet on their computer view TeamViewer software.

*Note: In order to provide support and take control of your tablet remotely, you partner needs to install and run the TeamViewer full version program in his computer, and have your TeamViewer ID. Visit

<http://www.teamviewer.com> for details.

11.2.3 Wireless Upgrade

This function allows you to perform an Over-the-Air (OTA) update, which can wirelessly deliver new operating system, software or data to the tablet.

*Note: While performing OTA update, please make sure the tablet battery has at least 70% and DO NOT run any other programs during the update.

11.2.4 File Explorer

The app features an application & files manager, task killer and download manager.

For more information, please refer to the associated ES file explorer documents.

12 J2534 Reprogramming Using SmartLink C

Reprogramming is often the only solution for problems ranging from driveability and loss of power to poor fuel economy and emissions related issues. SmartLink C makes it easy. The SmartLink C is a communication interface supporting J2534 specifications for ECU reprogramming.

Except that the SmartLink C acts as a VCI device and a SmartLink dongle, it also can be used as a J2534 PassThru device, working together with the PC installed with the OEM diagnostic software to perform the J2534 reprogramming. In this case, the PC needs to install with the LAUNCH's J2534 tool, which can be downloaded from www.cnlaunch.com.

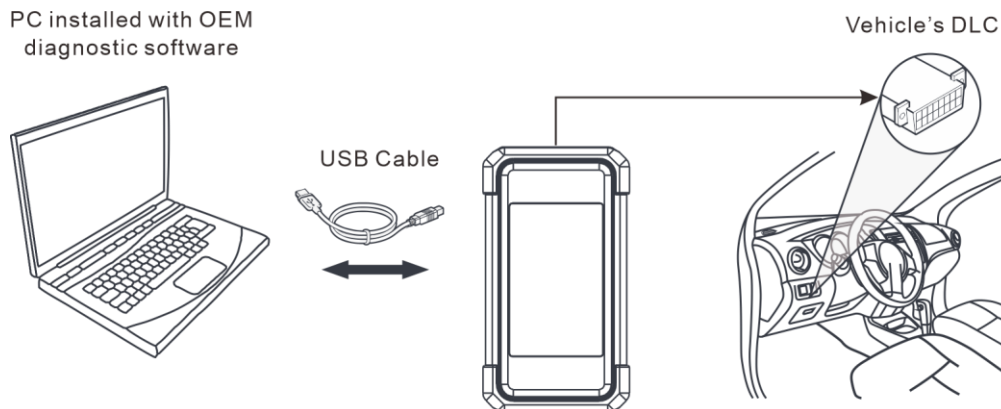

13 FAQ

13.1 About X-431 IMMO PAD

1. How to save power?

1. Please turn off the screen while the tool keeps idle.
2. Set a shorter standby time.
3. Decrease the brightness of the screen.
4. If WLAN connection is not required, please turn it off.

2. Communication error with vehicle ECU?

Please confirm:

1. Whether the VCI is correctly connected.
2. Whether ignition switch is ON.
3. If all checks are normal, send vehicle year, make, model and VIN number to us using Feedback feature.

3. Failed to enter into vehicle ECU system?

Please confirm:

1. Whether the vehicle is equipped with this system.
2. Whether the VCI is correctly connected.
3. Whether ignition switch is ON.
4. If all checks are normal, send vehicle year, make, model and VIN number to us using Feedback feature.

4. How to download the X-431 IMMO PAD App after resetting the tablet?

*Note: Before registration, please make sure the network is properly connected.

After the tablet has been successfully reset, follow the steps below to download the App:

1. Launch the browser and the default official Launch website opens (If a blank page pops up, just type in www.x431.com in the input bar).
2. Tap **Login**, input the username and password and tap **Log In**.
3. Make sure that the serial number is correct, tap **APP application program** and tap the Download icon to start downloading.
4. After the download is complete, follow the on-screen instructions to install it.
5. After installation, use the existing username and password to login and go to update center to download the diagnostic software.

5. What to do if the language of vehicle diagnostic software does not match the system language?

English is the default system language of the tool. After the system language is set to the preference language, please go to the update center to download the vehicle diagnostic software of the corresponding language.

If the downloaded diagnostic software is still displayed in English, it indicates that the software of the

current language is under development.

6. How to retrieve the login password?

Please follow below steps to proceed in case you forgot the login password:

1. Tap the application icon on the home screen to launch it.
2. Tap the **Login** button on the upper right corner of the screen.
3. Tap **Retrieve password**.
4. Input product S/N and follow the on-screen prompts to retrieve the password.

13.2 About SmartLink Diag.

1. What's network conditions is required for SmartLink Diag.?

The remote SmartLink Diag. operation requires a network broadband of 100 MB or above.

2. What does the word "Delay" displayed on the SmartLink C screen mean?

The Delay (network delay) indicates the state of the network communication, which can be regarded as a reference since different vehicles require different delays. Different colors represent different delay status. There are three states of network delay:

Green: Indicates a shorter network delay. In this case, it has a higher success rate of remote communication.

Yellow: Indicates a medium network delay. In this case, it has a medium success rate of remote communication.

Red: Indicates a longer network delay. In this case, it has a lower success rate of remote communication and remote ECU reprogramming operations are not suggested.

3. My network delay is so long.

Please check the following possible reasons:

1. The greater distance between the SmartLink B2.0/SmartLink B and SmartLink C V2.0 dongle causes a longer network delay.
2. There are too many network communication nodes that the data communication passes by, which may cause a longer network delay.
3. Check if the network is poor and data communication speed is slow.

4. Some systems of some old vehicles cannot be tested.

The SmartLink C V2.0 dongle supports CAN2.0/CANFD/DoIP communication protocols, but some old vehicle uses K-Line communication protocol.

5. Is it necessary to re-ignite the car after the diagnostic system starts working?

For the sake of some vehicle's conditions, the re-ignition will provide you a more detailed analysis after OBD diagnosis.

Warranty

This warranty is expressly limited to persons who purchase LAUNCH® products for purposes of resale or use in the ordinary course of the buyer's business.

LAUNCH® electronic product is warranted against defects in materials and workmanship for one year (12 months) from date of delivery to the user.

This warranty does not cover any part that has been abused, altered, used for a purpose other than for which it was intended, or used in a manner inconsistent with instructions regarding use. The exclusive remedy for any automotive meter found to be defective is repair or replacement, and LAUNCH shall not be liable for any consequential or incidental damages.

Final determination of defects shall be made by LAUNCH in accordance with stipulated procedures.

Order Information

Replaceable and optional parts can be ordered directly from your authorized tool supplier. Your order should include the following information:

- Quantity
- Part number
- Item description

Customer Service

If you have any questions on the operation of the unit, please contact local dealer, or LAUNCH TECH CO., LTD.:

Website: www.x431.com

www.cnlaunch.com

Tel: +86 755 8455 7891

Email: overseas.service@cnlaunch.com